

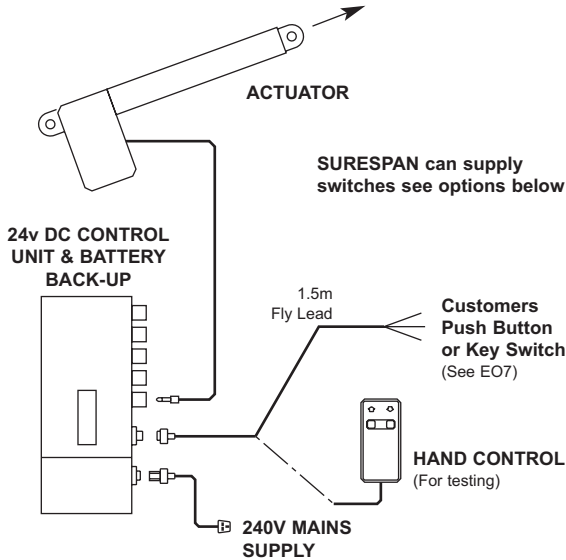

Electrically Operated Options I

EO1 - STANDARD SINGLE ACTUATOR



EO2 - SINGLE ACTUATOR/SINGLE SWITCH

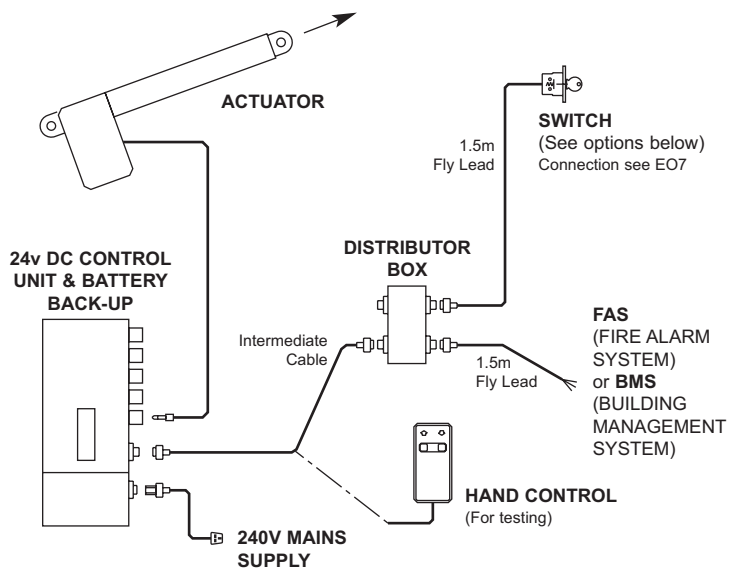

EO3- SINGLE ACTUATOR/DOUBLE SWITCH

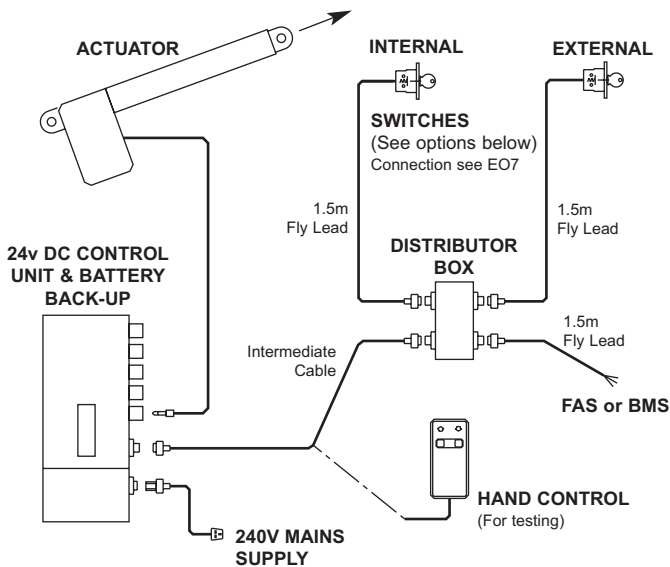

EO4 - DOUBLE ACTUATORS/DOUBLE SWITCH

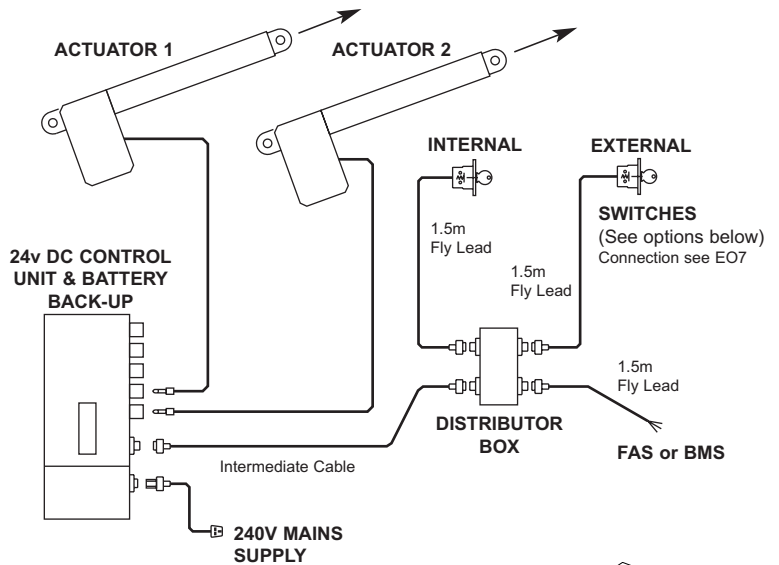

EX101

KEY SWITCH

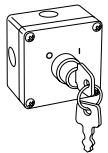

EX102

PUSH BUTTON

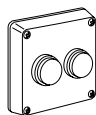

EX103

FIRE (BREAK GLASS)



EX104

SECURITY BOX FOR SWITCHES

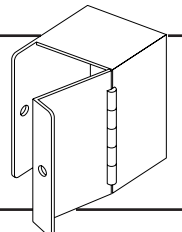

For further information contact:

Surespan Limited

Leamore Close, Leamore Enterprise Park

Walsall, West Midlands, WS2 7NL

Tel: +44 (0)1922 711185

Fax: +44 (0)1922 497943

Email: sales@surespancovers.com





Electrically Operated Options 2

EO5 - STANDARD ELECTRO-MAGNET SCHEMATIC

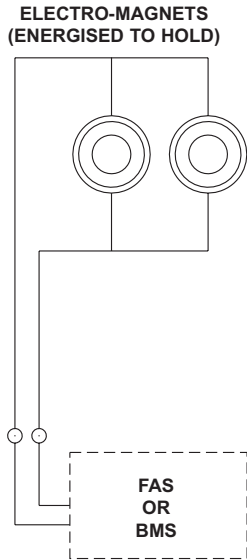

EO6 - OPTIONAL ELECTROMAGNET SCHEMATIC

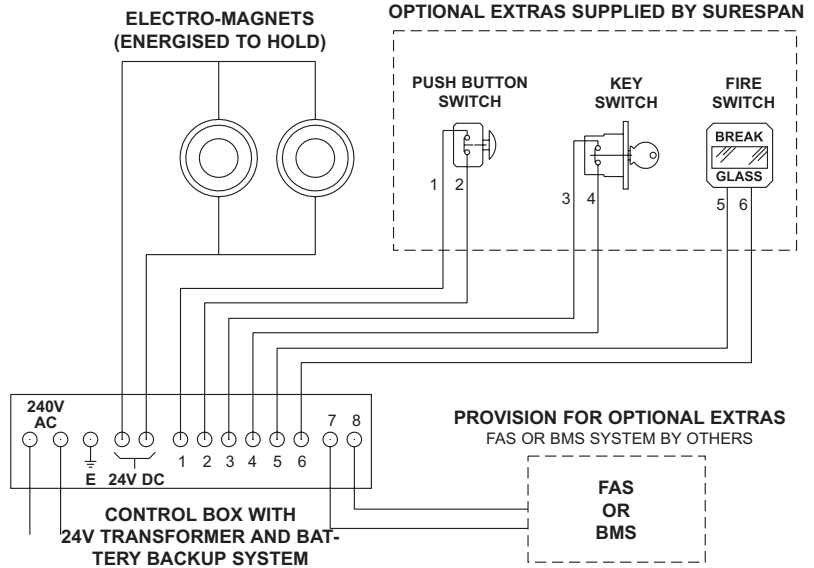

EO7 - WIRING DIAGRAM FOR HAND CONTROL/SWITCH CONNECTION

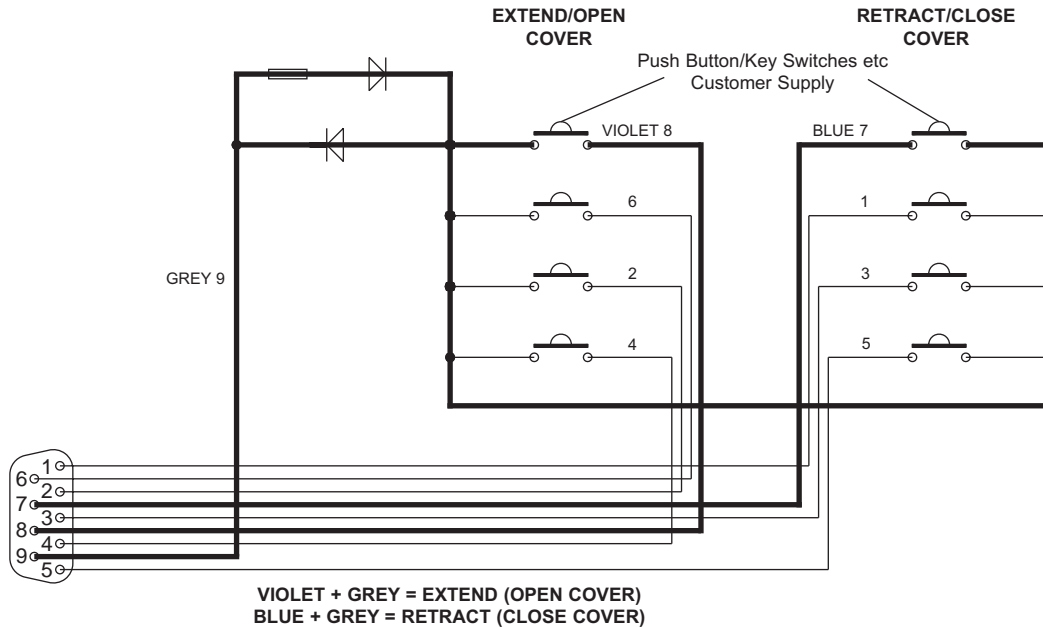

For further information contact:

Surespan Limited

Leamore Close, Leamore Enterprise Park
Walsall, West Midlands, WS2 7NL

Tel: +44 (0)1922 711185

Fax: +44 (0)1922 497943

Email: sales@surespancovers.com

